

*S15 Jimmy*

**GMC**  
TRUCK



**WITH 160 HP 4.3L VORTEC V6 POWER**

Top: Gypsy interior with available seat trim with leather inserts  
Center: New high-accuracy electric speedometer is standard.



4x4 Gypsy S-15 Jimmy shown with available equipment.  
Tires are supplied by various manufacturers.

# Gypsy

## ADVANCED PERFORMANCE AND TECHNOLOGY

...Beats all competition in V6 horsepower, torque & trailering

Why settle for an ordinary sport utility truck when you can have all the advantages of GMC Truck's S-15 Jimmy?

For instance:

- The available 4.3 Liter Vortec V6 rated at 160 SAE net horsepower @ 4000 RPM — the hottest V6 performance in S-15 Jimmy's class.
- The highest trailer-towing capacity in the compact sports utility field (excluding other GM products) — up to 6000 lb for properly equipped 2-WD models and 5500 lb for 4x4 models.
- New anti-lock rear brake system standard on all models (on 4x4 models, the anti-lock system operates only when in 2-WD).
- Shift from 2 WHEEL to 4 HIGH while operating at any speed. The Insta-Trac 4-WD system is always

ready with sure-footed traction for off-road driving or for highways covered with ice or snow.

There's also S-15 Jimmy's versatility to consider. It has city-sleek styling for driving around town, plus country-tough performance for weekend adventuring. All models can be equipped to carry four adults and their luggage. Or fold down the available rear seat and there's 67.2 cu ft of cargo space.

A choice of three trim levels includes top-of-the-line Gypsy, which comes with black chrome exterior accents, two-tone paint, color-keyed front and rear bumpers, Rally wheels on 2-WD models and other distinctive features.

Gypsy interior appointments start with high-back reclining front bucket seats trimmed in Deluxe Cloth in your choice of Saddle or Charcoal colors. Or specify available seating with

genuine leather seat trim inserts. Other standard features include color-keyed carpeting and instrument gage package.

S-15 Jimmy models offer substantial savings when purchased with available Value Packages. See page 12 for details.

<i>Index</i>	PAGE
Gypsy	2-3
Sierra Classic	4-5
Sierra	6-7
4x4 Models	8-9
Quality Features	10-11
Available Equipment	12
Value Packages	12
Exterior Colors	13
Trailering	13
Std. & Avail. Equipment	14
Technical Information	15



4x4 Gypsy S-15 Jimmy shown with available equipment. Tires are supplied by various manufacturers.

# Sierra Classic

## SPORTY STYLING WITH SPACIOUS COMFORT

Cross-town shopping or cross-country holiday, Sierra Classic looks good anywhere you take it.

Exterior styling features bright appearance items such as grille trim, wheel trim rings and wheel opening moldings. Its looks are made even more distinguished by color-keyed door handle inserts and black body side moldings with bright trim. Chrome bumpers with black rub strips are standard.

Step inside and discover luxury that's nothing short of a fine passenger car. Interior appointments are coordinated in your choice of Saddle, Charcoal, Carmine or new Dark Blue. There's also a choice of Custom Vinyl or Special Custom Cloth upholstery for the high-back front bucket seats.

Or select available reclining bucket seats with genuine leather seat trim inserts (Charcoal or Saddle colors only).

Other tasteful touches include full floor carpeting, carpeted rear quarter and endgate panels and full headliner. Gage-type instrumentation helps you keep track of what's happening under the hood.

Sierra Classic also comes with deluxe heater/defogger, special insulation, rearview mirror with dual reading lamps, right-hand visor mirror, tinted glass all around and much more.

A long list of available options lets you add to Sierra Classic appearance, comfort and convenience. See page 14 for more standard and available features.



Instrumentation includes a new high-accuracy electric speedometer. Standard full-gage instrument cluster shown. Electronic gage package with tachometer available.



Sierra Classic interior with Special Custom Cloth seat trim

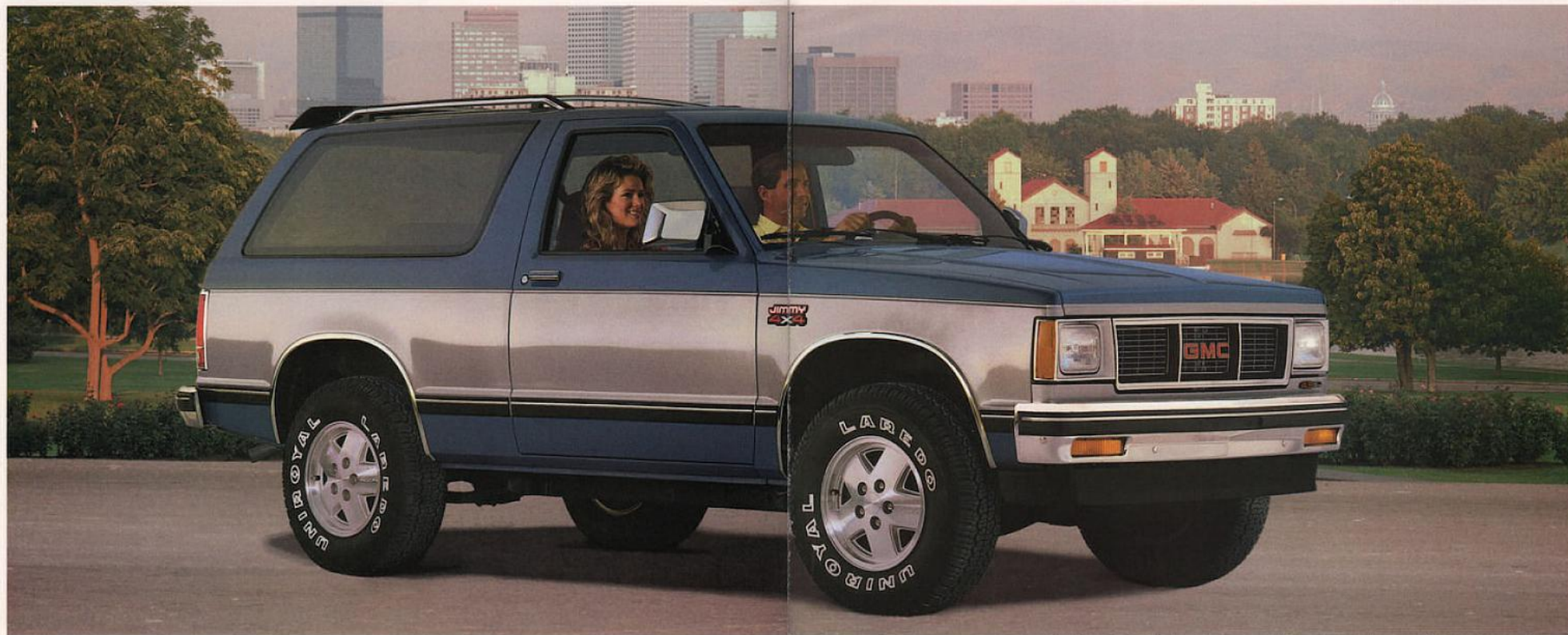

4x4 Sierra Classic S-15 Jimmy shown with available equipment. Tires are supplied by various manufacturers.

# Sierra

## STANDARD VALUE NEVER LOOKED BETTER

For versatility and value, Sierra S-15 Jimmy is tough to beat. It can be a personal vehicle, a fun truck or a work truck — or a combination of all three. And it comes with features you might not expect in a standard model.

The handsome interior can be ordered in Saddle, Charcoal, Carmine or Dark Blue. It includes high-back front bucket seats in Custom Vinyl, full headliner, color-keyed rubber floor covering, deluxe steering wheel, dual sunvisors and door panels with armrests and map pockets.

Sierra trim also is big on standard conveniences, such as front and rear dome lamps, left- and right-hand outside rearview mirrors, inside hood lock release and headlamp warning buzzer. Interior insulation and sound-deadening material help to suppress noise. All-season comfort is enhanced by a deluxe heater/ventilation system.

Like all S-15 Jimmy models, Sierra offers convenient rear cargo loading with a hinged lift-glass and swing-down tailgate. Small items can be lifted over the tailgate when the lift-glass is opened. Or lower the tailgate to load long cargo, such as lumber.

On the road, the standard 2.8 Liter V6 and 5-speed manual transmission provide impressive performance. If you'd like the tops in V6 performance, choose the available 4.3 Liter Vortec V6 and 4-speed automatic overdrive transmission combination.

See page 14 for the long list of both standard and available equipment. If you don't see what you are looking for, ask your GMC Truck Dealer salesperson.



2-WD Sierra S-15 Jimmy is built GMC Truck tough. Shown with available equipment.

### 2-WD MODELS

For those who don't need the extra traction of 4-WD, S-15 Jimmy with 2-WD makes an excellent family wagon for all-around city and highway driving. It's just as rugged as a 4x4 model and, when properly equipped, can pull gross trailer weights up to 6000 lb. Power brakes, including a new rear brake anti-lock system, as well as power steering and positive-traction All Seasons tire tread design are standard. Independent front suspension teamed with two-stage multileaf rear springs helps provide an impressive ride. And the 100.5" wheelbase contributes to impressive maneuverability. There's a choice of Sierra, Sierra Classic or Gypsy models, plus a long list of available equipment.



Sierra S-15 Jimmy interior with standard Custom Vinyl seat trim



2-WD Sierra S-15 Jimmy shown with available equipment. Tires are supplied by various manufacturers.

# 4x4 Insta-Trac

## FOR INSTANT 4-WHEEL TRACTION

Shift into 4-wheel drive and escape from the ordinary. S-15 Jimmy 4x4 models offer the most advanced features in their class.

For one thing, there's the instant action of GM's Insta-Trac system. One hand on the transfer case shift lever takes you from 2 WHEEL to 4 HIGH and back again, at any speed. It's way ahead of systems that require you to get out to lock or unlock the hubs, or to stop and reverse the truck to shift back into 2-WD.

For another, there's the trail-blazing performance of the available 4.3 Liter Vortec V6. It's the biggest, most powerful V6 you can get in a compact sport utility vehicle. Along with high horsepower, it delivers 230 lb/ft of torque at 2800 RPM. That's awesome power for pulling through mud or driving through tough terrain. Or for tackling rugged jobs like snowplowing or pulling a trailer. Plus, S-15 Jimmy provides the smooth ride and handling of torsion bar independent front suspension, which allows each front wheel to react individually to bumps and ruts. This

advanced system helps provide good tire-to-ground contact especially over rough terrain. That means impressive traction and stability on or off the road. The 4x4 models also are equipped with the new rear wheel anti-lock brake system as standard (operates only when in 2-WD). For added stability and riding quality there's a newly available off-road suspension package that includes high-pressure gas shock absorbers, heavy-duty torsion bars, special jounce bumpers, special stabilizer bar and tow hooks.



Insta-Trac transfer case provides shift-on-the-fly convenience.



4x4 S-15 Jimmy shown with Timberline sports trim package. See your GMC Truck Dealer for complete details. Tires are supplied by various manufacturers.

*Quality  
Built-In*

**SETTING TODAY'S  
STANDARD OF EXCELLENCE**

S-15 Jimmy is the compact utility truck with big-truck quality features. The quality begins with computerized design technology and continues through robotic assembly, paint and inspection procedures to produce a vehicle of outstanding appearance, comfort and strength. You can feel confident about S-15 Jimmy quality, because it's backed by

**GM's quality and excellent warranty coverage.** See your GMC Truck Dealer for details of the limited warranty.

**New rear wheel anti-lock brake system.** All S-15 Jimmy's have this system for stable, smooth stops, empty or loaded, on slick or dry pavements. On 4x4 models, the system operates only in the 2-WD mode.

**Front disc and rear drum brakes.** Front brake lining insulators help

assure quiet operation. Power brakes are standard on all models.

**Electronically fuel-injected V6 performance.** There's a choice of two lively V6 engines for S-15 Jimmy, both with computer-controlled Electronic Fuel Injection for quick starts and smooth driveability. A computer actually helps tune the engine as you drive.

**2.8 Liter V6.** Standard for all S-15

Jimmy models for '89, this advanced V6 provides plenty of performance. It produces 125 SAE net horsepower at 4800 RPM and 150 lb/ft of torque at 2400 RPM.

**4.3 Liter Vortec V6.** The most powerful V6 offered in any compact sport utility truck, the available 4.3 Liter Vortec generates 160 SAE net horsepower at 4000 RPM and a whopping 230 lb/ft of torque at 2800 RPM. That means power to spare for

highway driving, trailer towing or off-road adventuring. **Overdrive RPM Transmissions.** Overdrive allows the engine to operate at reduced RPM at highway cruising speeds, helping to prolong engine life. The standard 2.8 Liter V6 comes with a 5-speed manual overdrive transmission. The available 4.3 Liter Vortec V6 is teamed with an available 4-speed automatic overdrive transmission.

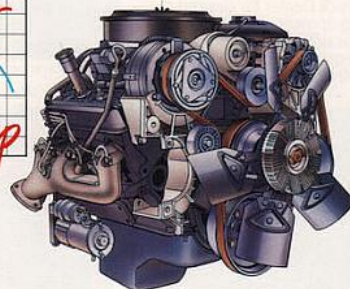
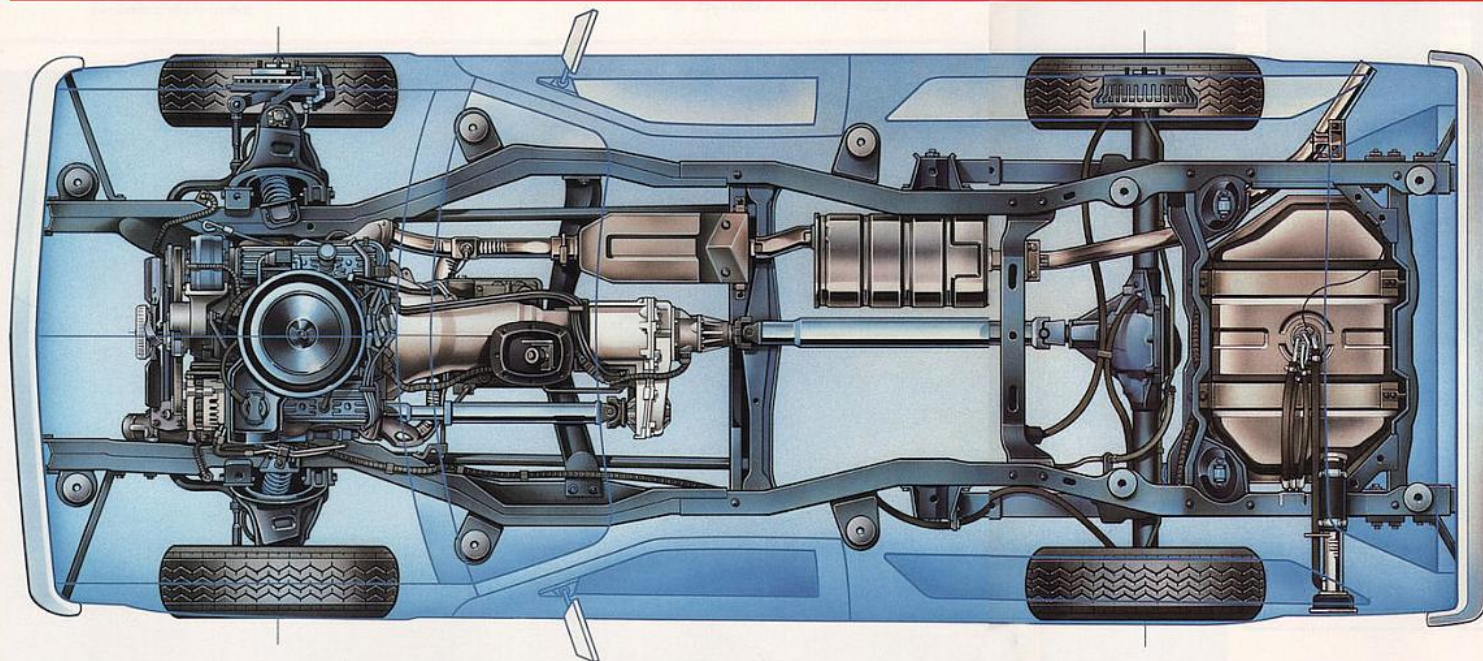

Available 4.3 Liter Vortec V6

**ENGINE TECHNICAL DATA**

ENGINE TYPE	GASOLINE	
	2.8L (175 CID) V6	4.3L (262 CID) V6
Displacement/ Configuration	2.8L (175 CID) V6	4.3L (262 CID) V6
Ordering Code	LL2	LB4
Bore and Stroke (in)	3.50 x 2.99	4.0 x 3.48
Compression Ratio	8.9 to 1	9.3 to 1
Fuel Delivery	electronic fuel injection	
SAE Net Horsepower @ RPM	125 @ 4800	160 @ 4000
SAE Net Torque (lb/ft) @ RPM	150 @ 2400	230 @ 2800

**A WORD ABOUT ENGINES**

GMC Trucks are equipped with engines produced by different operating units of GM, its subsidiaries or suppliers to GM worldwide.

**A quality ride.** S-15 Jimmy's independent front suspension helps keep you riding comfortably. Coil springs are used on 2-WD models, and torsion bars with 4x4 models. Both suspensions are designed to allow the front wheels to work independently of each other for an impressive ride and steady handling. Two-stage multileaf rear springs adjust to the load for a smooth ride, whether the vehicle is loaded or empty. Power steering is standard on all models.

**Rugged carbon steel frame.** S-15 Jimmy's frame comes on strong with a boxed front section and channel rear

section. The extra-strength boxed section helps take suspension punishment while supporting the weight of the engine and transmission. The entire frame is hot-wax coated to resist corrosion. A special coating on rear springs and axle also helps fight corrosion.

**Double-wall construction.** Inner and outer walls of steel are used in the hood, cowl, windshield pillars, front fenders, rear side panels, side doors and tailgate. Used in many full-size trucks, this type of construction adds strength and rigidity.

**One-piece fabrication.** Single stampings of major body panels

contribute to overall body rigidity. One-piece door-opening frames and welded-on hinges provide good fit, alignment and sealing of doors.

**Large fuel tank.** A big 20-gallon fuel tank provides long-range driving capability.

**Single-belt accessory drive.** All engines for S-15 Jimmy have a single-belt accessory drive instead of conventional multiple V-belts. It never needs adjustment and is designed for long wear.

**Easy service access.** S-15 Jimmy's clean, uncluttered engine compartment makes it easy to perform

routine service maintenance. See-through fluid reservoirs help speed service checks.

**Anti-corrosion measures:**  Coated steels for most body parts  8-stage zinc phosphate wash system  Cathodic Elpo dip primer  Anti-chip coating on rocker panels  Wax coating in door cavities and on frame, front stabilizer bar, rear axle and rear springs  Primer and finish acrylic enamel film build of 3.1 mils.

**GM-CAMS** is now installed at over 400 GMC Truck participating dealerships. GM-CAMS is an abbreviation for the Computerized

Automotive Maintenance System. It is designed to diagnose conditions related to electronic system and powertrain driveability problems in late model GM vehicles. GM-CAMS is not a replacement for other diagnostic tools, such as those used to diagnose traditional mechanical functions. CAMS' main function is to isolate malfunctions in electronic systems controlled by the vehicles' on-board computers. In addition, GM-CAMS permits access to a storehouse of information frequently used by technicians for routine repair, other than electronics.

# Available Options

## AVAILABLE QUALITY EQUIPMENT TO SUIT YOUR TASTES AND NEEDS

S-15 Jimmy offers a wide selection of available equipment. See Page 14 and check with your GMC Truck Dealer for desired equipment not listed in this catalog. Some items may require the purchase of other items.



Electronic instrumentation with tachometer



Delco AM stereo/FM stereo radio



Rear window wiper/washer



Comfortilt steering wheel\*



Power door locks and windows\*



Manually operated non-removable sunroof



Inside rearview mirror with dual reading lamps

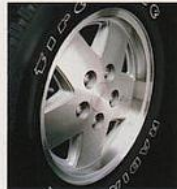

Cast aluminum wheels (4-WD only) +



Rally wheels (2-WD only) +

\* Receives C-QUAM® AM stereo broadcasts. Most AM stereo stations across the country broadcast in C-QUAM but some do not. Check with your local stations for compatibility in your area.

+ Part of a package. See your GMC Truck Dealer for details.  
+ Tires are supplied by various manufacturers.

# Value Packages

Buy an S-15 Jimmy with an available Value Package and save! Savings are based on Manufacturer's Suggested Retail Price for Value Package versus options purchased separately. Ask your Light Duty GMC Truck Dealer for discount details.

### Ordering Instructions:

- You may add options to these packages; however, **NO DELETIONS ARE ALLOWED WITHOUT THE LOSS OF DISCOUNT.**
- Available upgrades:
  - A) May be upgraded to A11 Deep-Tinted Glass.
  - B) May be upgraded to Exterior Spare Tire Carrier.
  - C) May be upgraded to AM/FM Stereo Radio with Seek-Scan, Stereo Cassette Tape & Digital Clock, or to AM Stereo/FM Stereo Radio with Seek-Scan, Stereo Cassette Tape with Search and Repeat, Graphic Equalizer & Digital Clock.
  - D) May be upgraded to Black Luggage Carrier.
  - E) May be upgraded to High Country Package (4-WD models only).
  - F) May be upgraded to AM Stereo/FM Stereo Radio with Seek-Scan, Stereo Cassette Tape with Search and Repeat, Graphic Equalizer & Digital Clock.
  - G) May be upgraded. See your GMC Truck Dealer.

	PACKAGE 1		PACKAGE 2		PACKAGE 3	
	2WD	4WD	2WD	4WD	2WD	4WD
<b>Base Value Package</b>						
Base Trim	•	•				
Gage Package	•	•	I	I	I	I
Rally Wheels	•	•	I	N/A	I	N/A
Deep-Tinted Glass with Light-Tinted Rear Window (A)	•	•	•	•	•	•
Halogen Headlamps	•	•	•	•	•	•
Folding Rear Seat with Shoulder Belts	•	•	•	•	•	•
Reclining Front Seat Backs	•	•	•	•	I	I
Spare Tire Cover (B)	•	•	I	I	I	I
AM/FM Stereo Radio (C)	•	•				
<b>Sierra Classic Value Package</b>						
Sierra Classic Trim			•	•		
Luggage Carrier (Bright) (D)			•	•		
Below Eyeline Exterior Mirrors (Bright) (E)			•	•	•	•
AM/FM Stereo Radio with Seek-Scan, Stereo Cassette Tape & Digital Clock (F)			•	•	•	•
Underhood Lamp			•	•	•	•
<b>Air Conditioning</b>						
Console			•	•	I	I
P205 White-Lettered Tires (G)			•	•	•	•
Floor Mats—Color Keyed: Front			•	•	•	•
Floor Mats—Color Keyed: Rear			•	•	•	•
Comfortilt Steering Wheel & Intermittent Wipers			•	•	•	•
<b>Speed Control, Electronic Instrumentation, Electronic</b>						
Speed Control, Electronic Instrumentation, Electronic			•	•	•	•
<b>Gypsy Value Package</b>						
Gypsy Trim			•	•	•	•
Operating Convenience Package (Power Windows & Locks)			•	•	•	•
AM Stereo/FM Stereo Radio with Seek-Scan, Stereo Cassette Tape with Search and Repeat, Graphic Equalizer & Digital Clock			•	•	•	•
Cast Aluminum Wheels (E)			N/A	•	•	•
Below Eyeline Exterior Mirrors (Painted)			•	•	•	•
Luggage Carrier (Black)			•	•	•	•
Rear Window Delogger (Electric) & Power Tailgate Release			•	•	•	•

N/A - Not applicable • Required I - Included in another option within package

# Trailer

## TOWING CAPACITY AT THE TOP OF ITS CLASS

S-15 Jimmy offers more trailer-towing muscle than any other compact sport utility truck, excluding other GM vehicles. A properly equipped 2-WD S-15 Jimmy with available 4.3 Liter V6 engine can move gross trailer weights of up to 6000 lb — that includes trailer, passengers and cargo in the trailer and equipment on the truck and trailer (4x4 models can tow up to 5500 lb).

To help you properly equip your S-15 Jimmy for trailering, you can order from the factory either of two trailering equipment packages. The light-duty package is designed for trailers with a maximum weight of



Properly equipped, 4-WD S-15 Jimmy can tow gross trailer weights up to 5500 lb.

2000 lb. The heavy-duty package is recommended for trailers up to 6000-lb maximum weight. This package along with the available 4.3L V6 engine enables you to move up to 9500-lb Gross Combination Weight

which includes S-15 Jimmy, trailer, passengers, cargo and equipment — everything going down the road. For detailed information about trailering, ask your GMC Truck Dealer for a 1989 Trailering Guide.

# Exterior Colors



Aspen Blue (M)



Emerald (M)



Apple Red

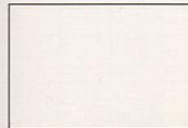

Frost White



Galaxy Blue (M)



Nevada Gold (M)



Steel Gray (M)



Midnight Black



Wheat



Woodlands Brown (M)



Silver (M)  
(Secondary 2-tone color only)

NOTE: Due to printing irregularities, colors shown may vary from actual tones. Ask your dealer to show you actual paint chips. (M) = Metallic



**Conventional Two-Tone paint**, standard on Gypsy and available for all other models, extends lower accent color around entire vehicle (including front and rear bumpers if vehicle is equipped with painted bumpers). Includes body side and wheel opening moldings on Sierra models.



**Special Two-Tone paint** scheme for all models includes coordinated upper decal stripe to separate upper main color from lower accent color, but available 4-stripe Sunshine Stripping (not shown) may be specified. May be substituted for Conventional Two-Tone on Gypsy models at no extra cost.



**Deluxe Two-Tone paint** scheme for all models except Gypsy extends middle accent color around to front and rear of vehicle. Black body side moldings and bright wheel opening moldings included on Sierra (standard on Sierra Classic).





**GMC**  
TRUCK

LET'S GET IT  
TOGETHER.



BUCKLE UP!



Quality Network



Protection  
Plan

**GMAC**

For warranty information on vehicles described in this brochure see your GMC Truck Dealer. The available GM Protection Plan provides additional protection during and after the new-vehicle limited warranties. Your GMC Truck Dealer has details.

When it comes to financing or leasing a new GM vehicle, General Motors Acceptance Corporation can make it easy. With GMAC, the entire transaction is handled right in the dealer's showroom. Rates are competitive and

terms are tailored to fit your circumstances. For many people, leasing a new truck through GMAC is an ideal way to suit their transportation needs. Ask your GMC Truck Dealer for details.

